



# JUMBO LOK P/N 1070

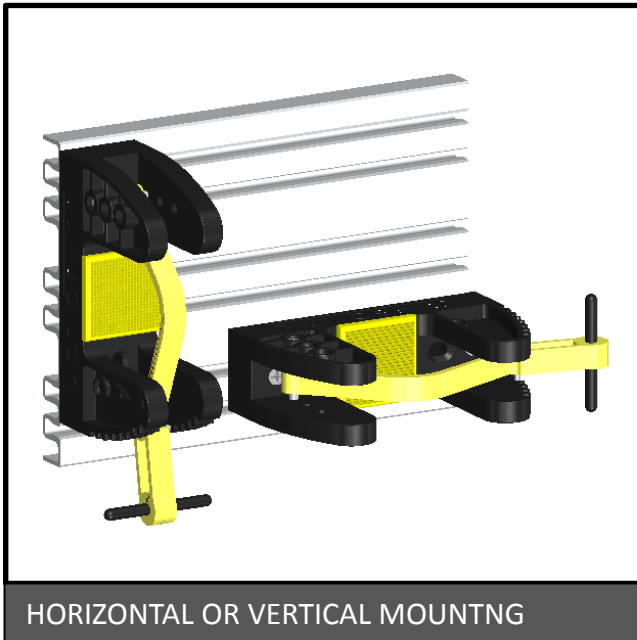
# INSTALLATION INSTRUCTIONS







For additional assistance call 888-514-0083 between 8AM-5PM EST or email: info@pactoolmounts.com

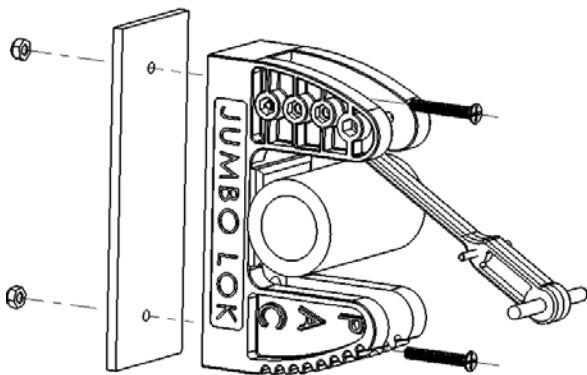
## CAUTION

To avoid the risk of personal injury, property damage or product damage, please use the included fasteners for mounting.

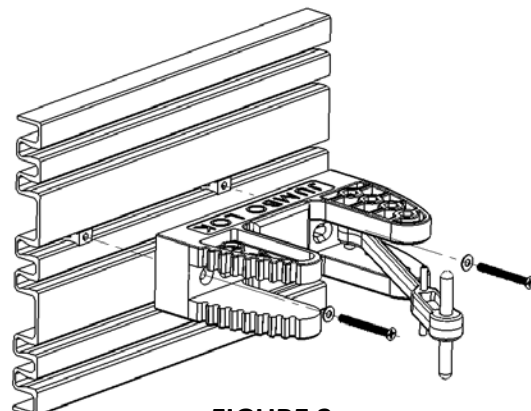
- \* The bracket must be securely mounted to a stable surface and material.
- \* When mounting bracket to PAC TRAC aluminum products **P/N 7000, P/N 7020, P/N 7040, P/N 7050** with the included Trac Lok inserts **P/N 7016**, torque the screws to a maximum 15 in-lbs.
- \* PAC recommends regular and frequent inspections to be certain of proper operation and installation.



PAC Fastener Packet P/N 7042			
STANDARD MTG. HARDWARE			QTY
	P/N 2092	¼-20 x 1-3/4 S.S. Flat Head Screw	2
	P/N 2069LN	¼-20 S.S. Locking Hex Nut	2
PAC TRAC MTG. HARDWARE			QTY
	P/N 2022	#10-24 x 1-7/8 S.S. Flat Head Screw	2
	P/N 2054	#10 S.S. Flat Washer	2
	P/N 7016	TRAC LOK INSERT	2
	P/N 2096	WRENCH	1

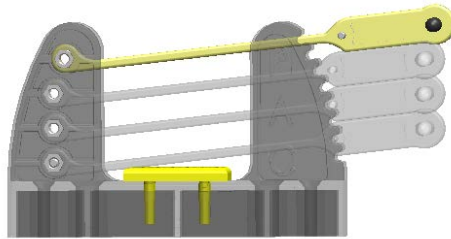


**FIGURE 1**  
(Thru Mounting Method)



**FIGURE 2**  
(PAC TRAC Mounting)

# STEP 1 –Reposition or Replace the Lock Strap



## 4 Strap Positions

The **Jumbo Lok** bracket provides 4 pivot positions for attaching the lock strap to adjust the grip range. In the lowest position, the **Jumbo Lok** can secure items as small as 3/8". Lock strap position can be determined by the size and shape of the item secured.

Using the included **Wrench P/N 2096**, remove the bolt from bracket base and reposition to the desired position. (See figure 2)

