

Electric Motor Driven

# Submersible Pump

Model SX11

Size 2"



## PUMP SPECIFICATIONS

**Size:** 2" (50.8 mm)**Pump Casing:** Gray Iron**Motor Casing:** Stainless Steel**O-Rings:** Nitrile Rubber**Wetted Hardware:** Stainless Steel**Impeller:** Gray Iron**Rotor Shaft:** Stainless Steel**Lip Seal:** Nitrile Rubber**Seal:** Oil Lubricated. Double. Mechanical. Carbon/Ceramic Upper Seal Faces. Silicon Carbide/Ceramic Lower Seal Faces. Fluorocarbon Elastomers (DuPont Viton® or Equivalent).

## MOTOR/CABLE SPECIFICATIONS

**Power Cable:** 3 Wire (2 Power Conductors, 1 Ground), 14/3 AWG, Type STOW (PVC). 50 Ft. (15 m) Long**Phase/Hz/Voltage:** 1/60/115V**1 H.P.** 3400 RPM 13. Full Load Amps**Standard Equipment:** Lifting Handle. 2" (51 mm) NPT Discharge Adaptor. Built-in Thermal Overload Protection.

*\*Consult Factory for Applications Exceeding Maximum Pressure and/or Temperature Indicated.*



GORMAN-RUPP PUMPS

www.grpumps.com

Specifications Subject to Change Without Notice

Printed in U.S.A.

**Specification Data**

**SECTION 130, PAGE 242C**

APPROXIMATE  
DIMENSIONS and WEIGHTS

**PUMP and CABLE NET WEIGHTS:\***

**54 LBS. (24,5 KG.)**

**\*Add 6 LBS. (2,72 KG.) to Net Weights for Cartoned Weights.**

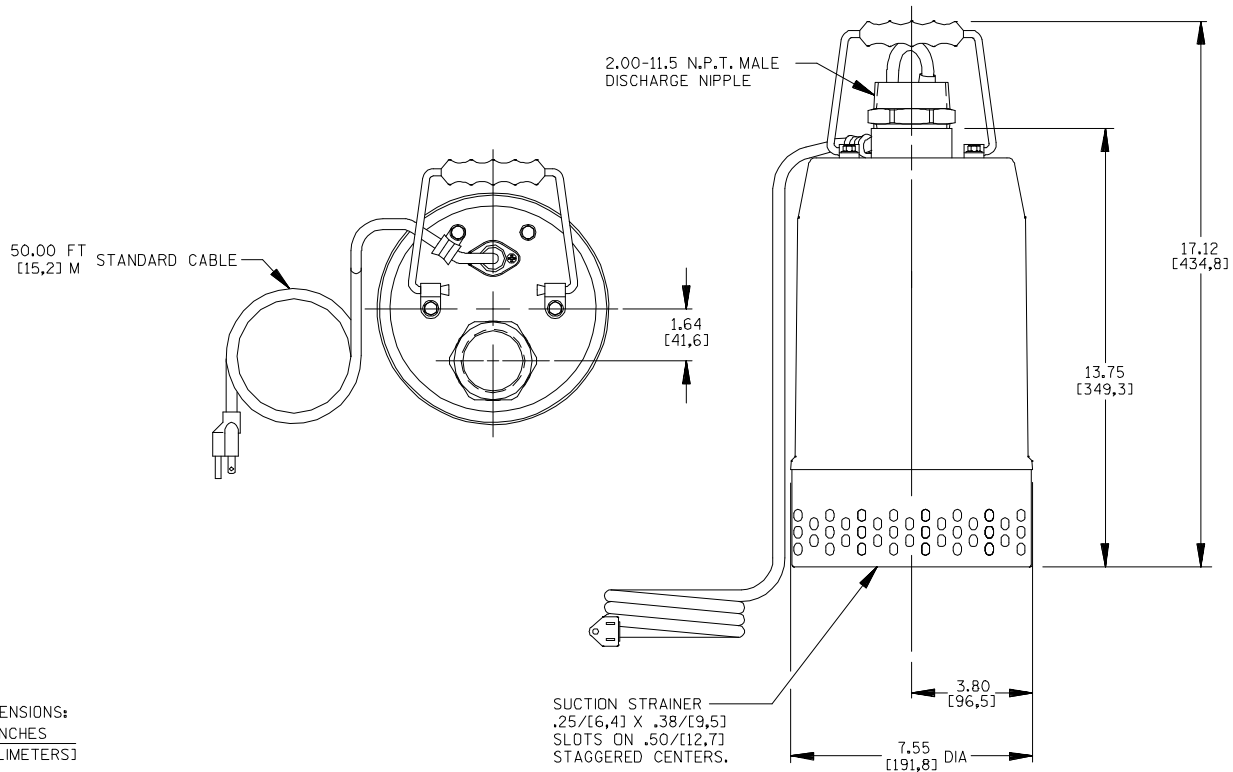

DIMENSIONS:  
INCHES  
[MILLIMETERS]

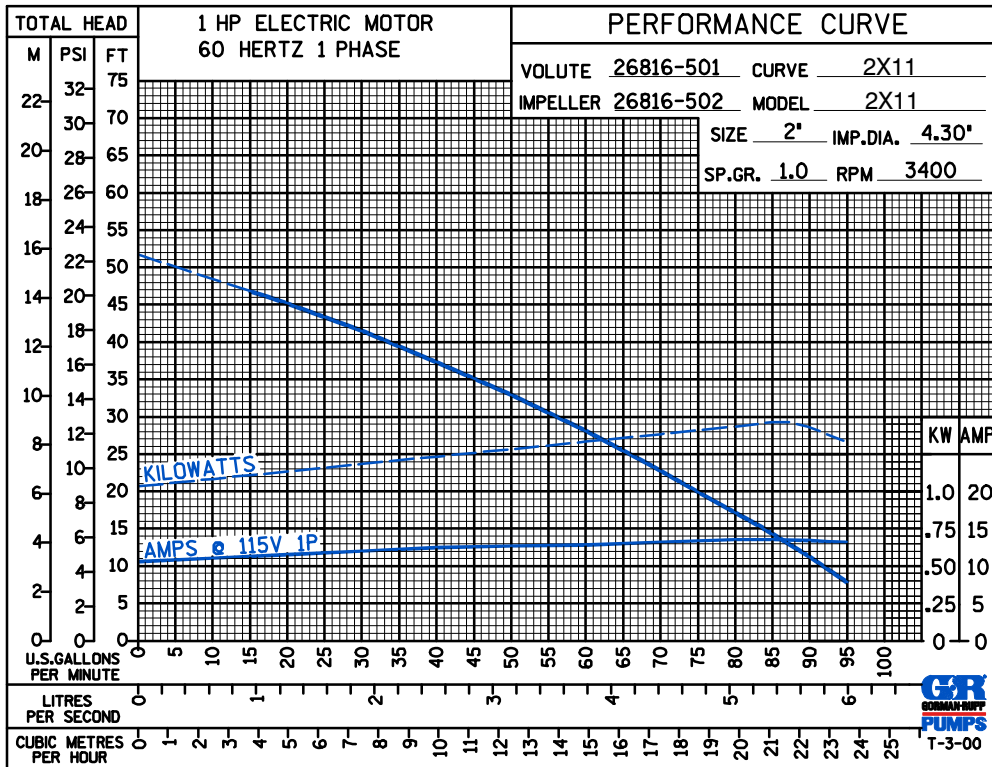

**GORMAN-RUPP PUMPS**

www.grpumps.com

Specifications Subject to Change Without Notice

Printed in U.S.A.